



YORK® CHECK AND FOOT VALVES

103 YORK® check valve



MATERIALS

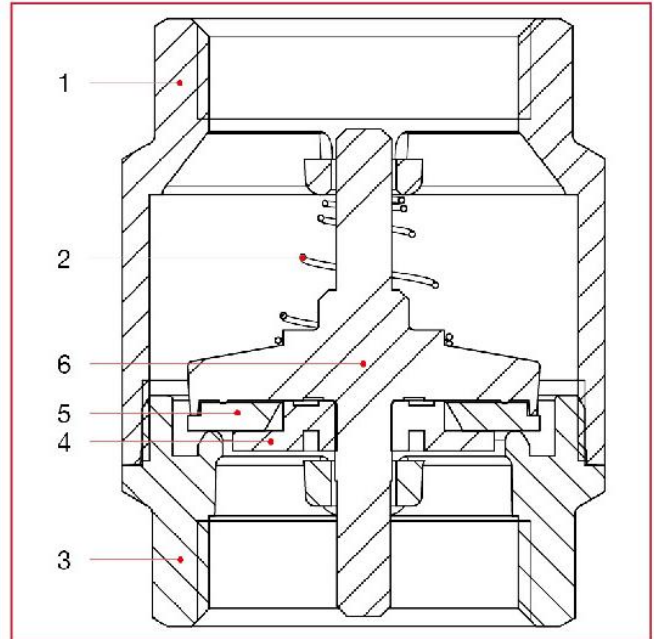

OVERALL DIMENSIONS

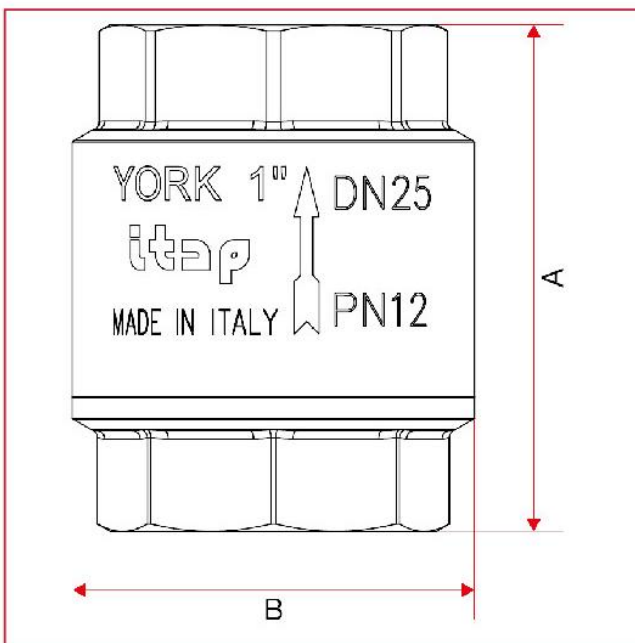

POS.	DESCRIPTION	N.	MATERIAL
1	Body	1	Brass CW617N
2	Spring	1	Stainless steel AISI 302
3	End adapter	1	Brass CW617N
4	Pin	1	Polymer
5	Washer	1	NBR
6	Plate	1	Polymer

	3/8"	1/2"	3/4"	1"	1"1/4"	1"1/2"	2"	2"1/2"	3"	4"
DN	10	15	20	25	32	40	50	65	80	100
A	46,5	48	53	60,5	66,5	74	80,5	98	103	118,5
B	35	35	42	48	59,5	70,5	86	103	126	154
Kg/cm ² bar	12	12	12	12	10	10	10	8	8	8
LBS - psi	174	174	174	174	145	145	145	116	116	116