



EUROPA® CHECK AND FOOT VALVES

100 EUROPA® check valve



MATERIALS

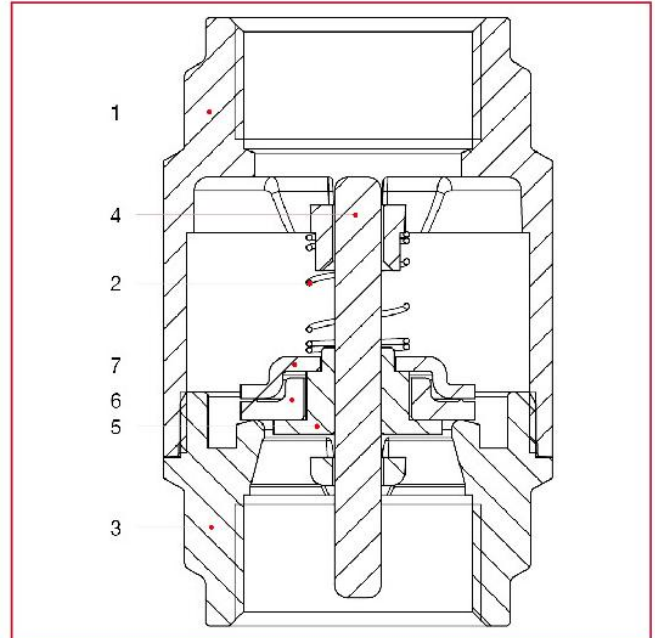

OVERALL DIMENSIONS

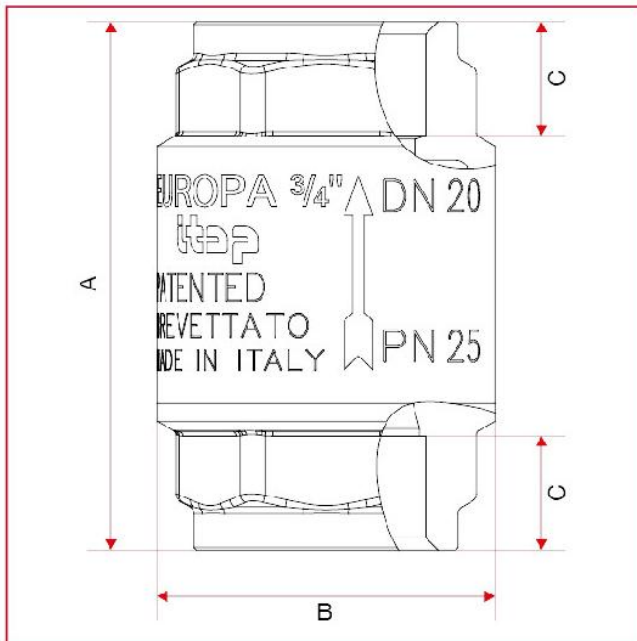

POS.	DESCRIPTION	N.	MATERIAL
1	Body	1	Brass CW617N
2	Spring	1	Stainless steel AISI 302
3	End adapter	1	Brass CW617N
4	Pin	1	Brass CW614N
5	Cap	1	Brass CW614N
6	Washer	1	NBR
7	Plate	1	Stainless steel AISI 304

	3/8"	1/2"	3/4"	1"	1"1/4	1"1/2	2"	2"1/2	3"	4"
DN	10	15	20	25	32	40	50	65	80	100
A	55	58,5	65	74,5	83	93	101	122	141,5	158,5
A (NPT)	-	61	65	74,5	83	93	101	122	141,5	159,5
B	34,5	34,5	41,5	48	60,5	71	87	120	140	172
C	10,5	11,5	14	16,5	18,5	20,5	21	24	28	28
Kg/cm2 bar	25	25	25	25	18	18	18	12	12	12
LBS - psi	362,5	362,5	362,5	362,5	261	261	261	174	174	174